

Enquiry No. IIITDMJ/P&S/Enq./14

Date: 3/8/2011

Sub: Invitation of Tender/Quotation for the Supply of Furniture (Tables, Chairs & Stools) specifications as per Annexure-I & Annexure-II

Sealed Tenders are invited by the Director, PDDM Indian Institute of Information Technology, Design & Manufacturing Jabalpur for Supply of Furniture for Library & ECE Lab (Tables & Chairs) specifications as per Annexure - I & Annexure - II enclosed.

The tender No., closing and opening date of received quotations are as follows:

Tender No.: No. IIITDMJ/P&S/Enq./14	Dated : 3/8/7/2011
Closing Date & Time: 22/8/2011	3.00 PM
Date & Time of opening of Technical : 22/8/2011	4.00 PM

General Terms and Conditions:

1. Sealed pack quotations are invited from reputed suppliers capable of supplying branded furniture of standard make in accordance with the technical specifications given in Annexure-I & Annexure-II.
2. **Make:** Any standard make having ISO 9000 and ISO 14000 certified furniture manufacturers who has authorized distributor and service center at Jabalpur.
3. **The bid: should be in three parts:**
 - (a) **Technical bid:** Consisting of technical details complying with the required technical specifications mentioned in Annexure-I & Annexure-II (In a separate cover)
 - (b) **Financial bid:** Indicating price for the items mentioned in the technical bid. (In a separate cover)
 - (c) **EMD:** The bidder must submit the EMD (bid security) in separate cover. If the EMD is not found valid in terms of amount-wise, period-wise or otherwise, the technical bid of the bidder will not be opened. The technical bid, financial bid and EMD Should be sealed

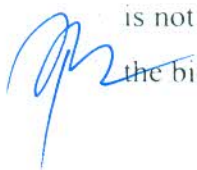

by the bidder in separate covers duly super scribed and then the sealed covers are to be put in bigger cover which should also be sealed and duly super scribed.

4. The quoted rates should be F.O.R. destination i.e. PDPM-IIITDM Jabalpur, Dumna Airport Road, P. O. Khamaria, Jabalpur, Madhya Pradesh - 482005.
5. Payment will be released 90% on delivery and 10% against satisfactory installation/ inspection report.
6. Institute reserves the right to change the quantity as per its requirement at any stage. Further the Institute reserves the right to place order either of all the items or only some of the above items. The supplier shall have no right to claim any compensation in such case.
7. The supplier is to submit earnest money deposit (EMD) of Rs. 35,000/- (Rupees Thirty Five Thousand only) with their sealed quotation. Quotation without earnest money deposit shall be summarily rejected.
8. The earnest money deposit (EMD) should be in the form of FDR or Demand Draft in favour of "Director, PDPM-IIITDM payable at Jabalpur. The EMD should remain valid for a period of 45 days beyond the final tender validity period
9. Validity of quotation should be minimum 90 days from the date of opening of quotation.
10. **Delivery Period:** Delivery of all the items should be completed within 4 weeks from the date of receipt of firm order.
11. **Penalty for delayed Delivery:**
In the event of delayed delivery, Installation & Commissioning i.e. after the expiry of the period as mentioned in P.O., the vendor shall be liable for a penalty deduction at a percentage of the value of the undelivered equipment subject to a maximum of 7.5% as detailed below:
 - @ 1% up to one week;
 - @ 2.5% up to two weeks;
 - @ 5% up to three weeks;
 - @ 7.5% for four weeks and above

For the purpose of this clause, part of the week is considered as a full week.

12. The quotations should be completed in all respects and cover the cost for the materials of the exact specification and descriptions of the stores as per the annexure-I & annexure -II, otherwise the same shall be ignored.
13. **Authorization Certificate:** In case of distributor of any branded company supplier has to submit authorized Agent/Dealership Certificate issued by their principal against the items quoted.
14. **Warranty:** Warranty should be at least one year from the date of installation of the supplied items. During warranty period the purchaser will not bear the cost of the item (s), which may come as replacement of the original stores or spares as a result of faults noticed at the time of inspection during the warranty period. The Seller/Local Agent is required to eliminate the fault (s) occurring during the Warranty period without delay by improvement or replacement as may be necessary, at their own cost. During warranty period, the supplier should ensure a maximum downtime of 48 hours from the date/time of the complaint lodge about the item. The supplier must provide after sales service facility on site during warranty period.
15. **Performance Bank Guarantee:** During Warranty Period supplier has to submit PBG @ 5% of the total cost of the items supplied. PBG should remain valid for a period of 60 days beyond the date of completion of warrantee.
16. **Inspection & Testing:** Goods will be inspected by the purchaser at his end. Goods rejected on inspection will be replaced by the supplier of cost and all charges for collection and delivery of the same to the Purchaser will be on suppliers account.
17. Director, PDPM-IIITDM, Jabalpur reserves the rights to himself/herself to alter/modify the order at any stage and or to reject any offer without assigning any reason thereof and he is not bound to accept the lowest tender.
18. Any attempt of negotiations direct or indirect on the part of the tenderer with authority to whom he has submitted the tender unless called by the competent authority or any endeavor to secure any interest for an actual or prospective tenderer or to influence by any means, the acceptance of particular tender will render the tender liable to exclusion from consideration.

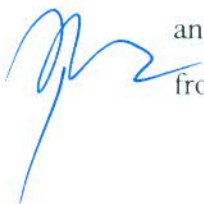

19. **Eligibility Criteria:** A bidder must have proven track record in supplying the specified items/similar items to the educational institutions/reputed organizations and should be financially sound and should have own showroom & service centre at Jabalpur.
20. The Institute reserves the right to reject any or all bids without specifying any reasons thereof.
21. All disputes should be within the jurisdiction of Jabalpur.
22. Kindly enclose pamphlet/brochure of the company along with the quotation showing complete details, technical specifications and quality of the items.
23. Sealed quotation, mentioning "Tender No. IIITDMJ/P&S/Enq./14 at the top of the envelop, should reach on or before 3.00 PM on 22/8/2011 to the Registrar, PDPM-IIITDM Jabalpur, Dumna Airport Road, Post: Khamaria, Jabalpur (M.P.) Pin-482005.
24. Technical bid will be opened at 4.00 PM same day (22/8/2011) in case of holiday, technical bid will be opened at the same time on next working day.

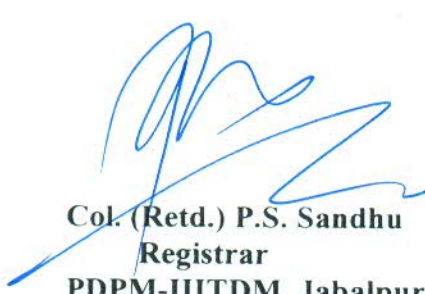

Col. (Retd.) P.S. Sandhu
Registrar
PDPM-IIITDM, Jabalpur

Technical Specification for Modular Furniture

GENERAL SPECIFICATION

WORK TOP:-

Made of 30mm thick wooden Top with round moulding at the front

The door of drawer at fronts are provided with Nylon Buttons for noiseless working

The doors are mounted to the modules by hinges which are openable to 95 degree & self closing on return

Storage module with Level adjusting screws to adjust Storage Unit level by + - 10 mm.

HARDWARE FITTINGS:

Hinges, Handle, Screw and Elec. Fittings all part should be ISI Marked.

Note : - We attaching rough drawing of Table and their part for help to make proper design & Laboratory table.

dmh
26-07-11

detachable

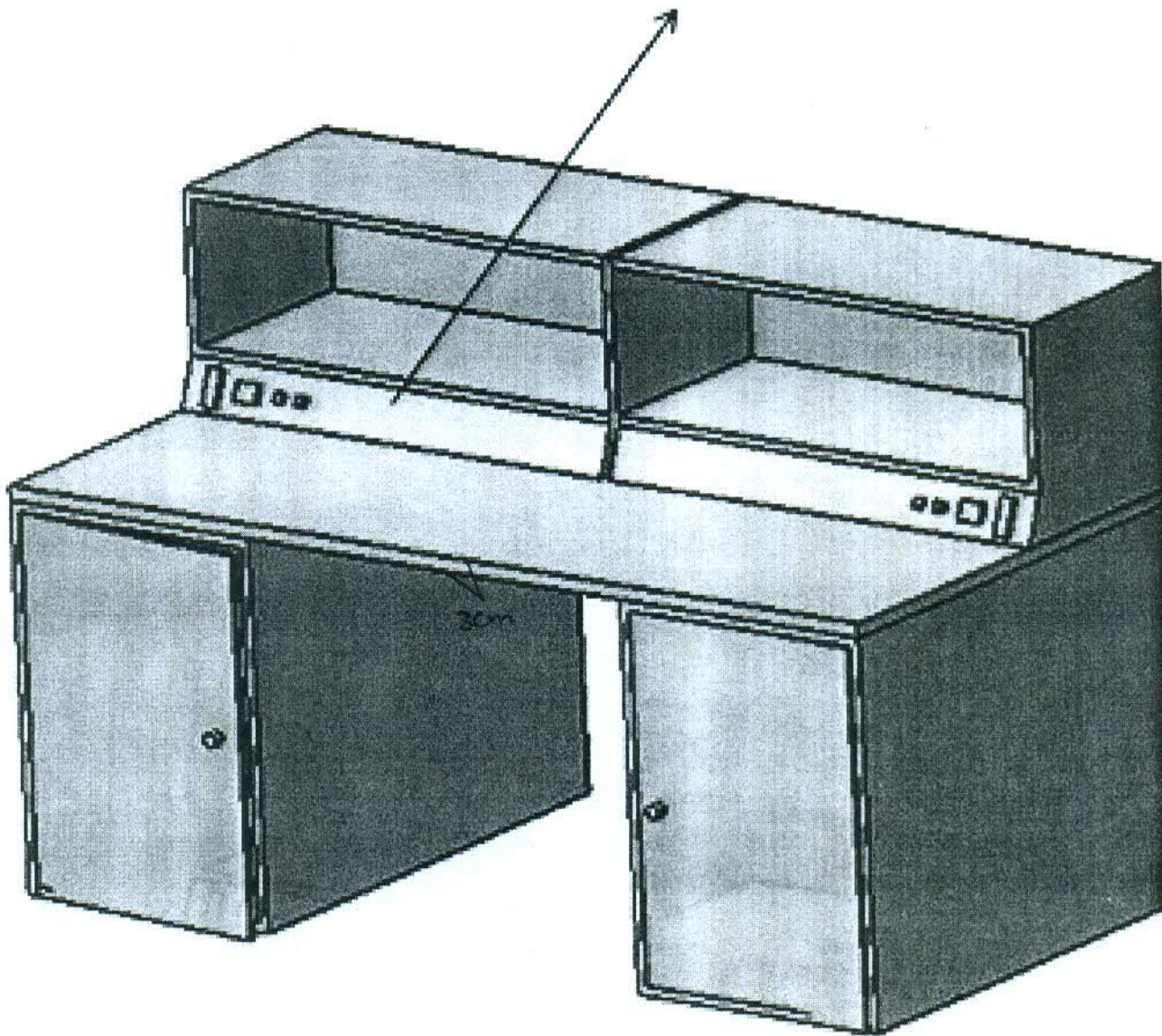

Dr. h
26.07.11

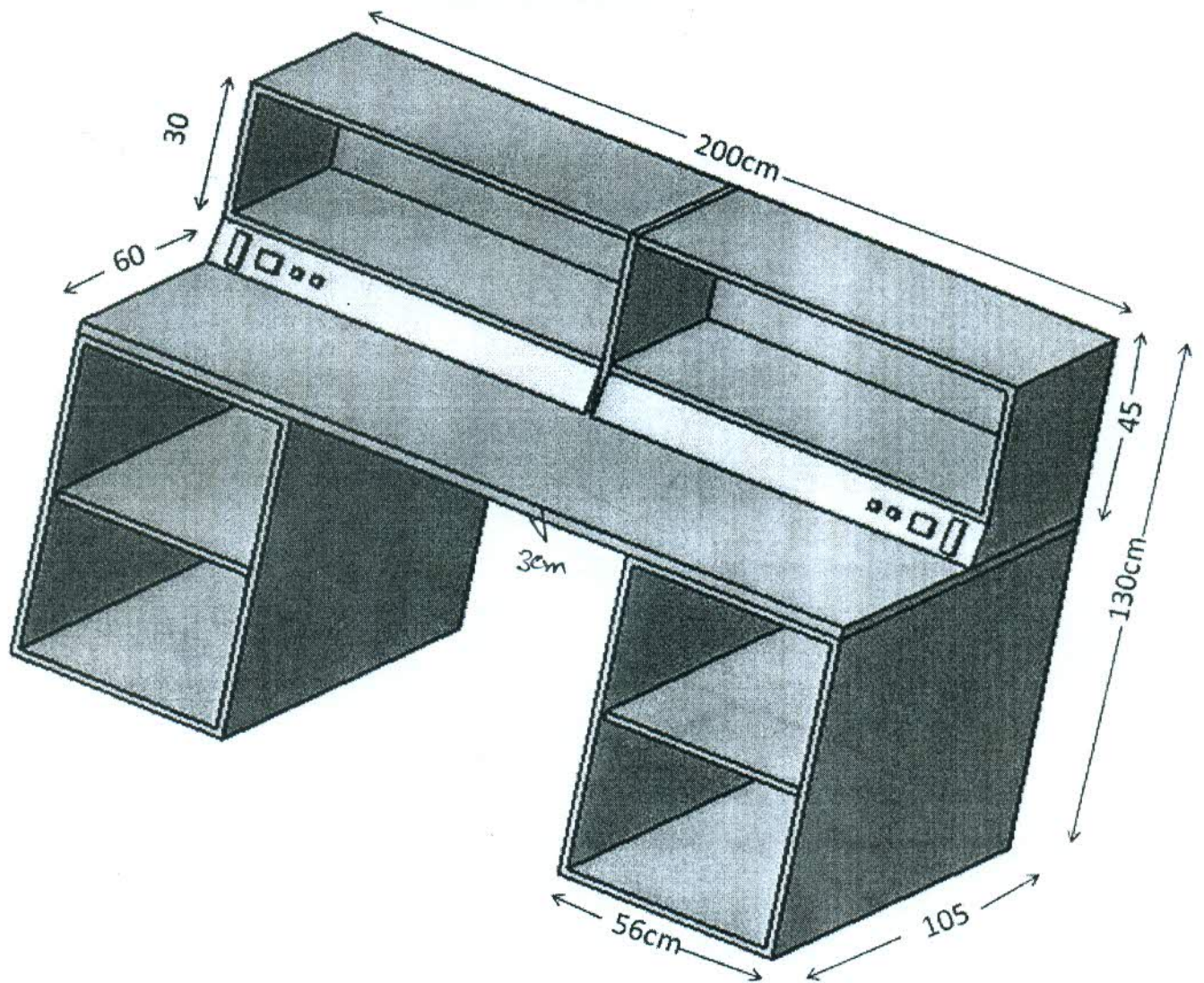

dim
26.07.11

Holes for electric wires

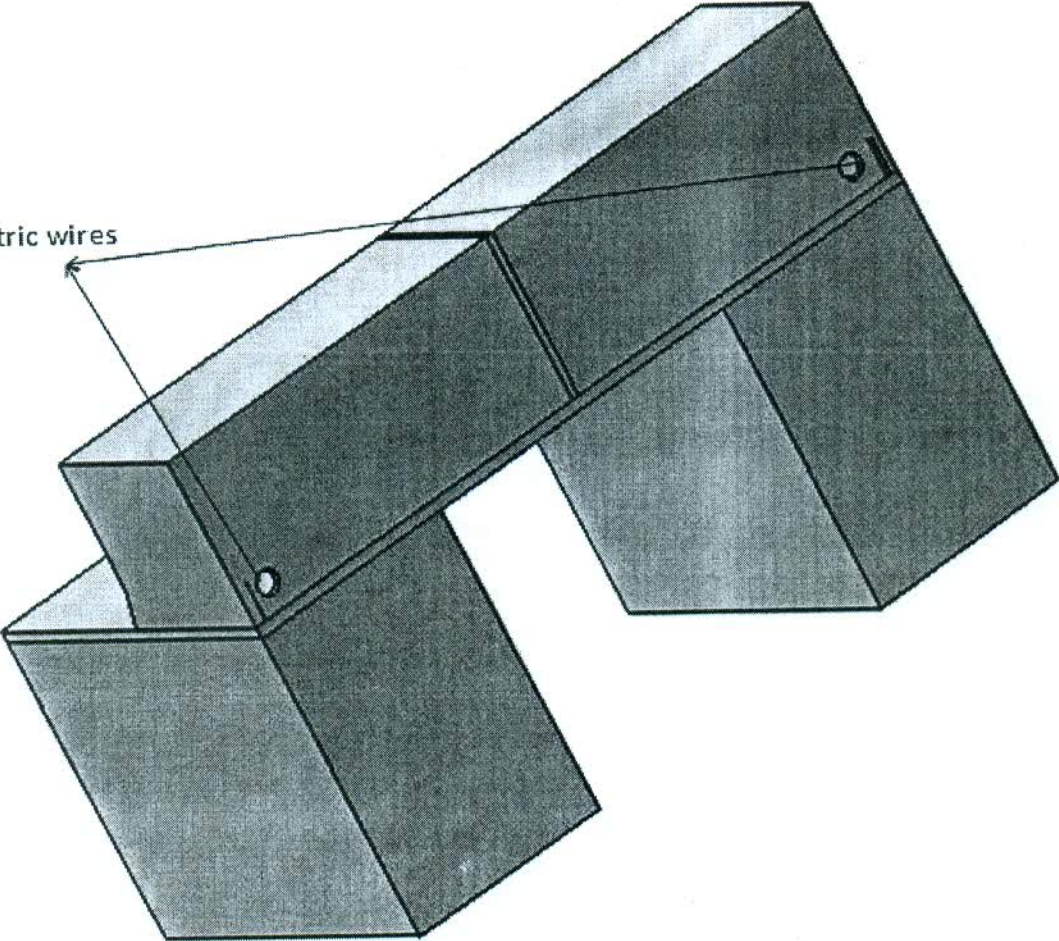

dh
26.07.11

Cabinet

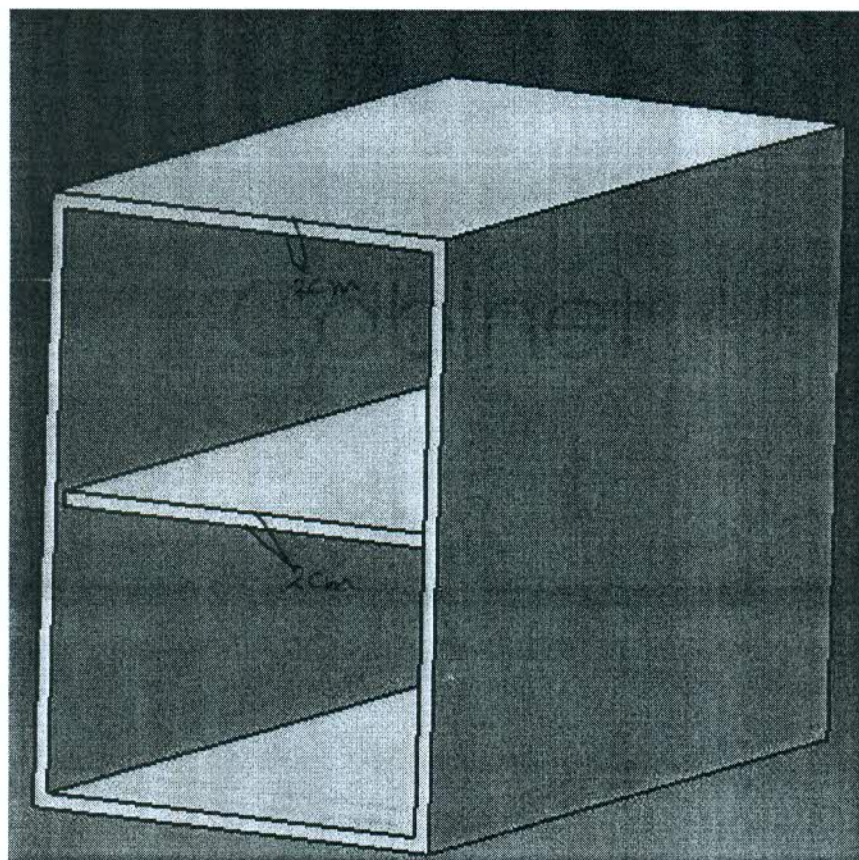

Dmh
26-07-11

Cabinet Door

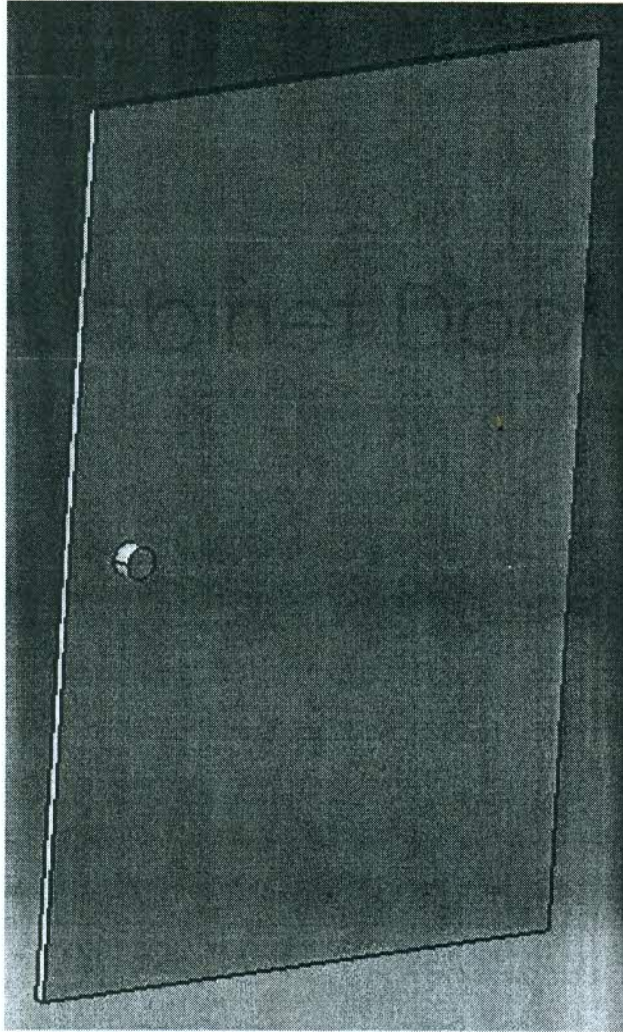

dmh
26.07.11

Left side top shelf

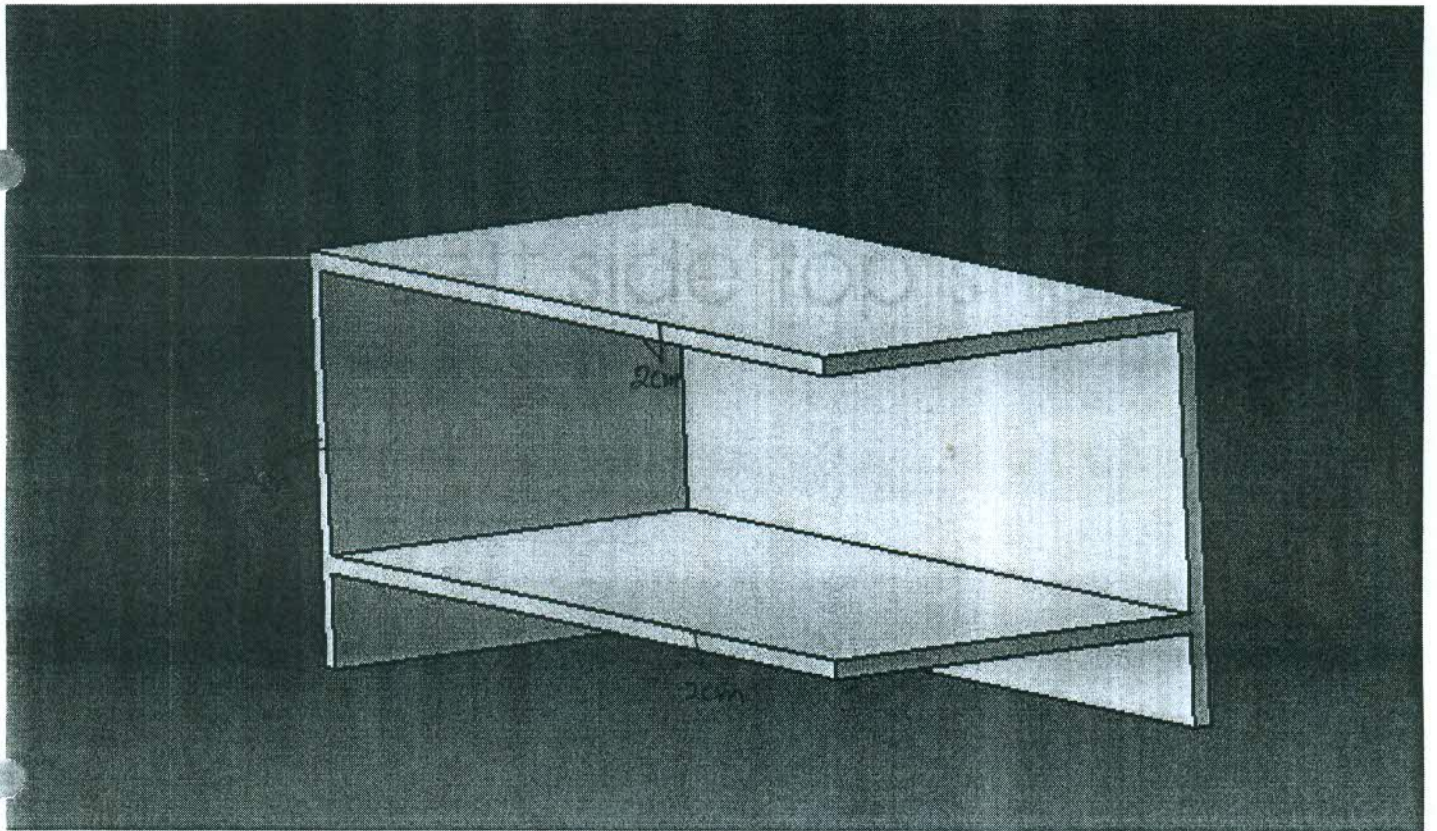

Jim
26.07.11

